

Battery interface

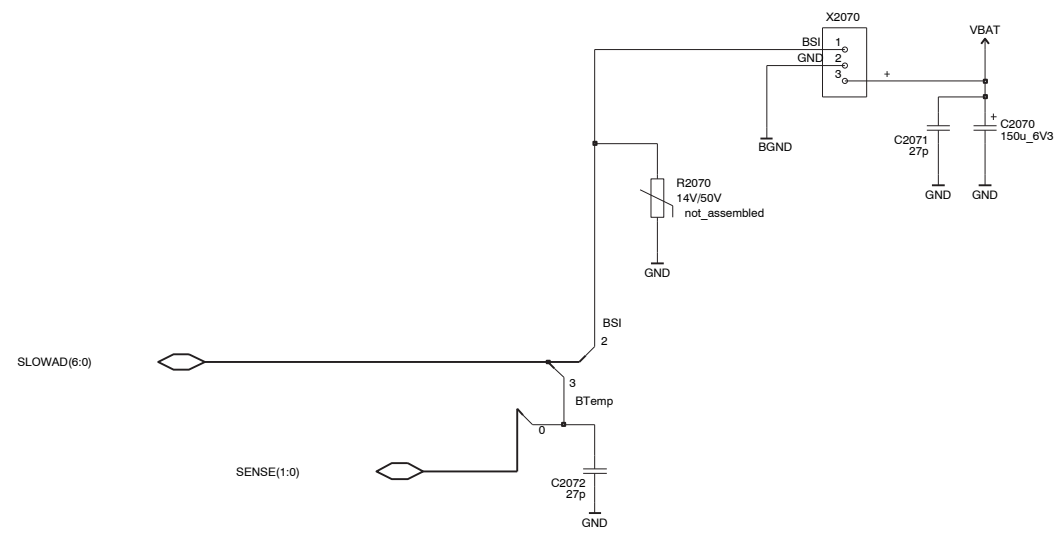

### Headset

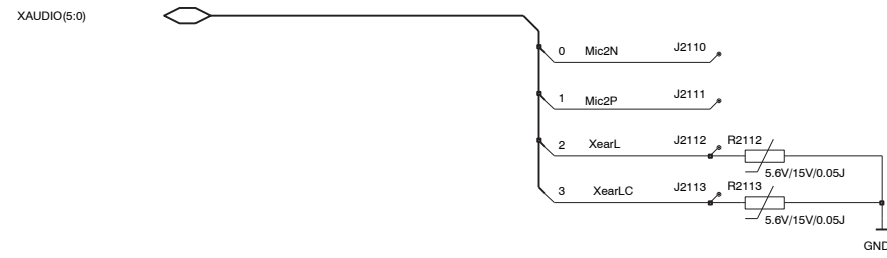

### Earpiece

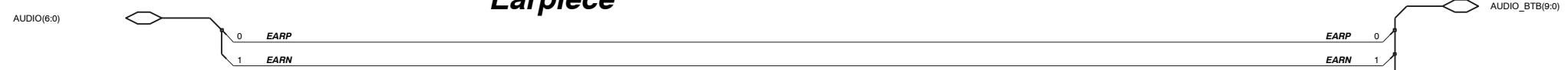

### Microphone

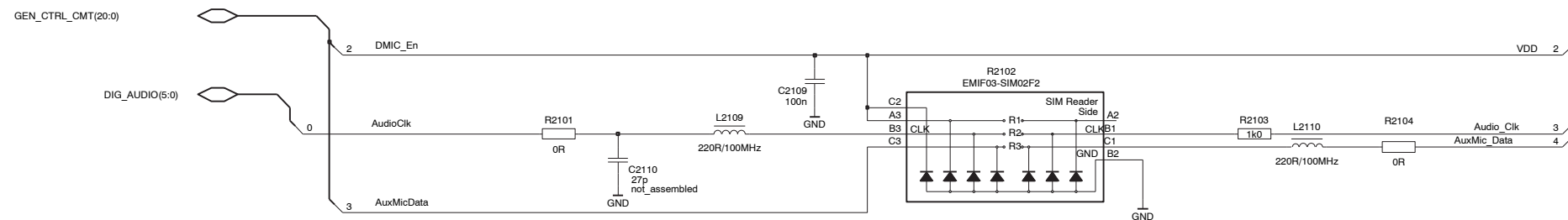

### Vibra

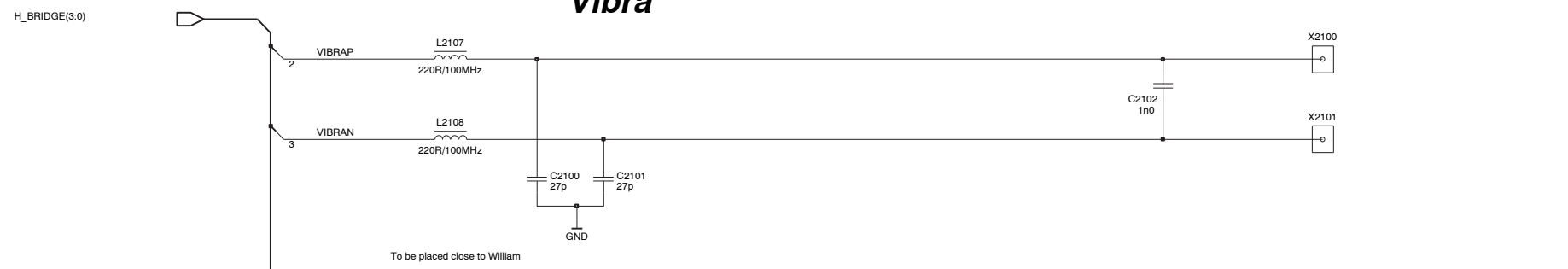

### IHF

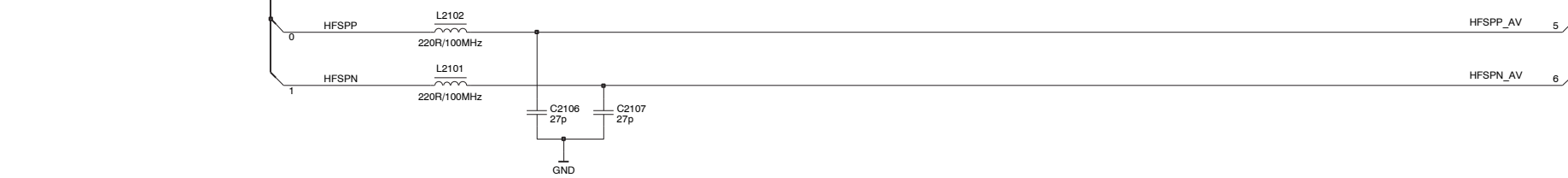

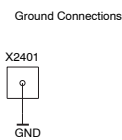
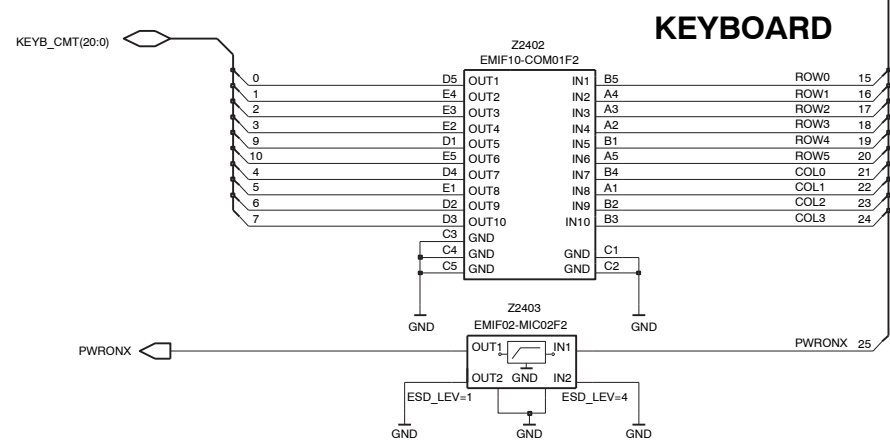
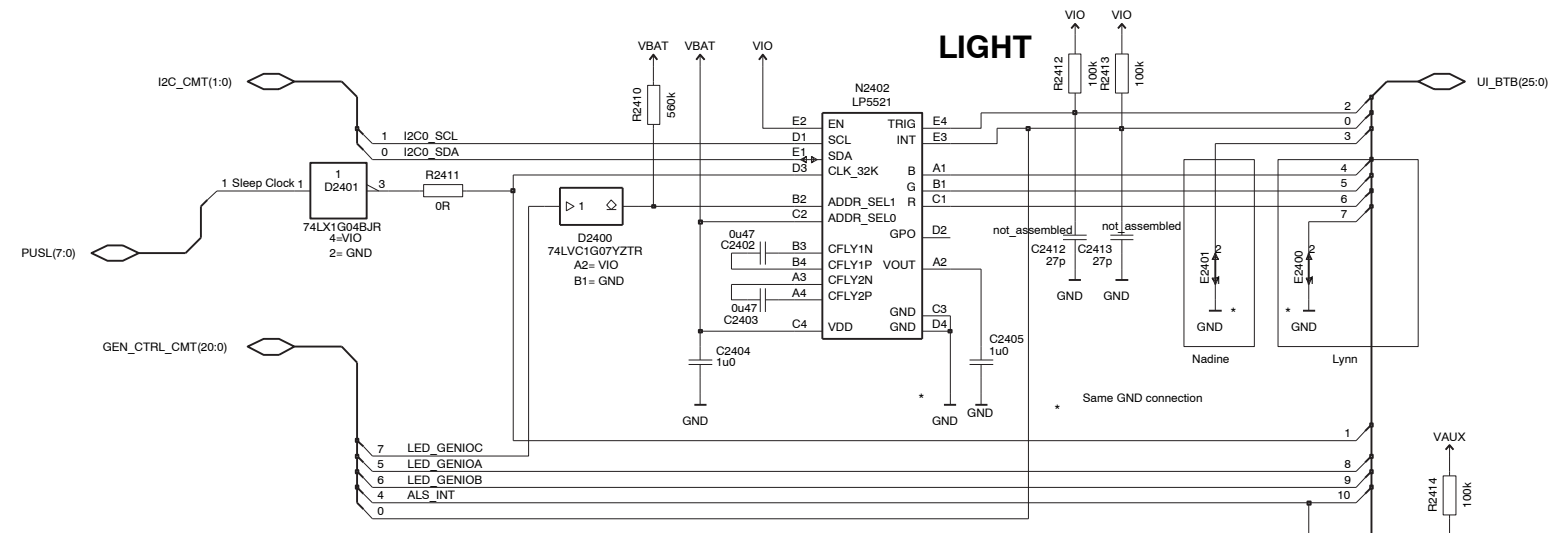
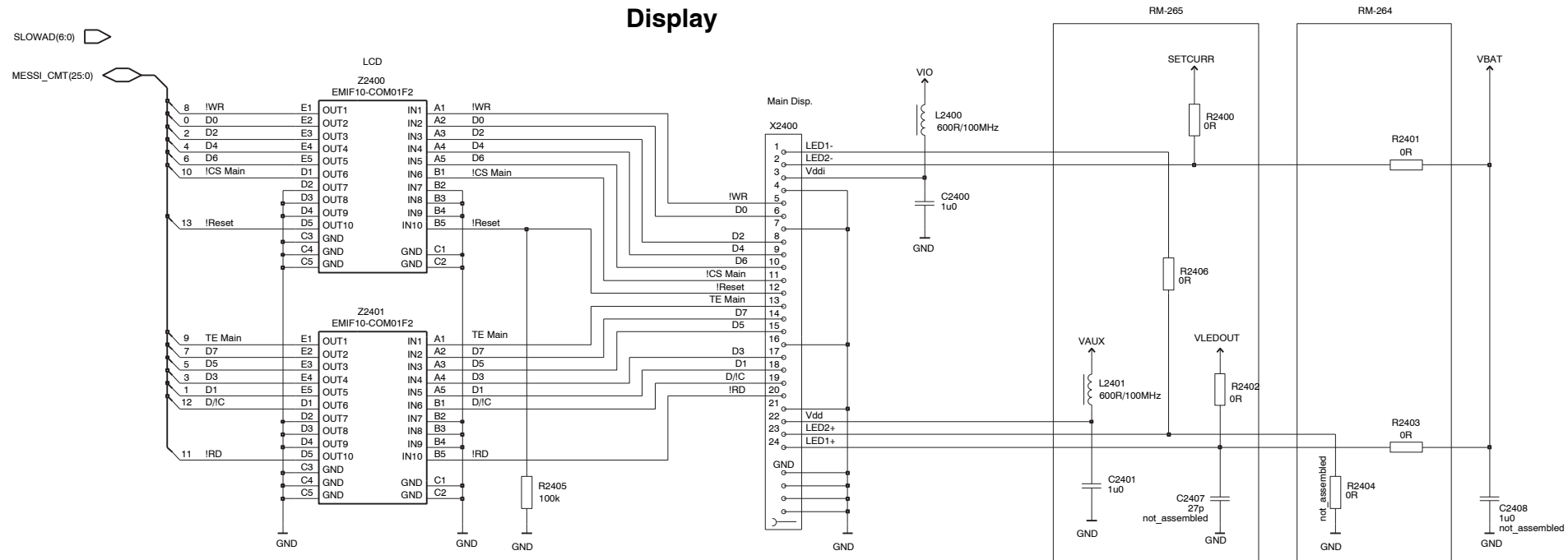

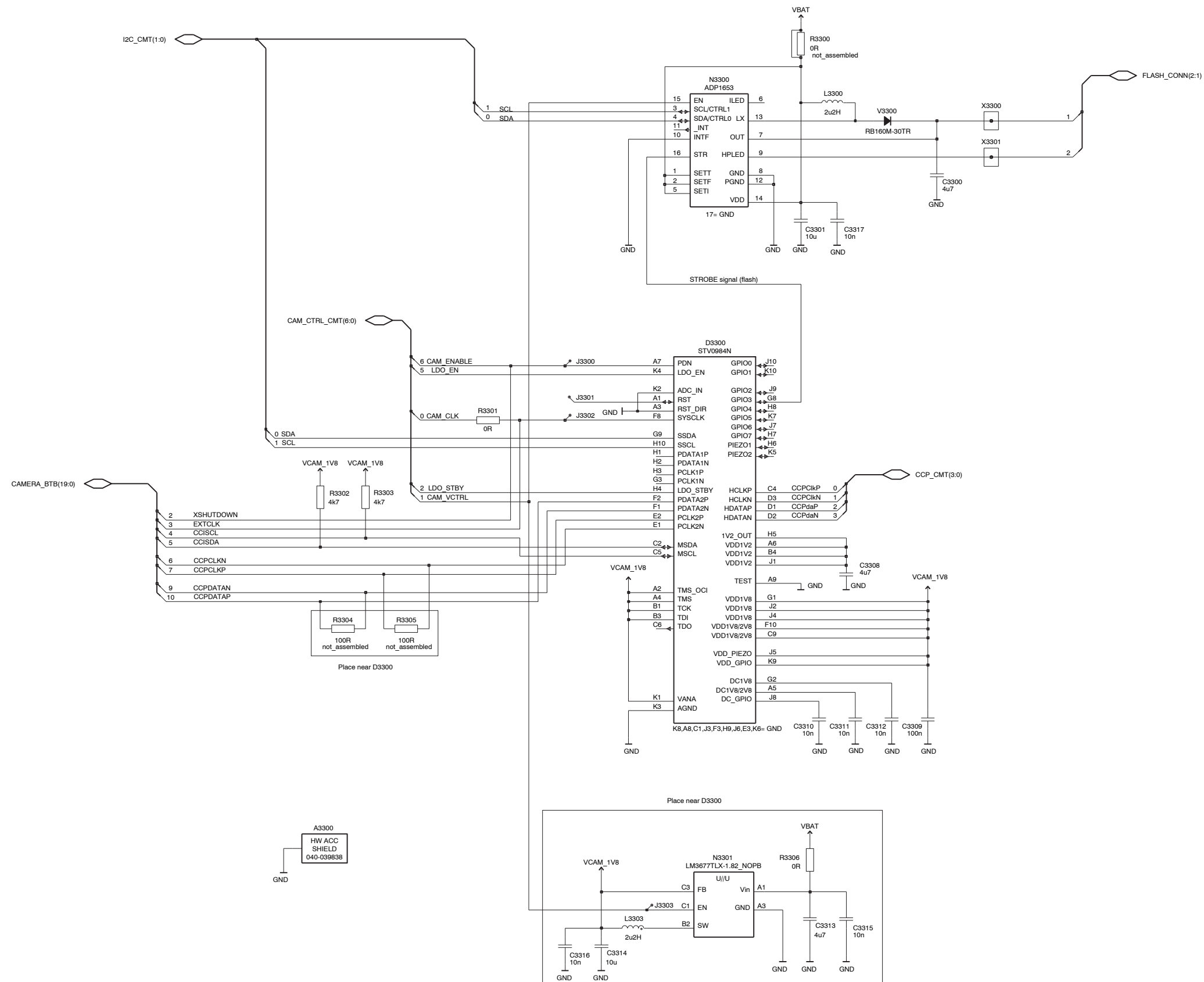

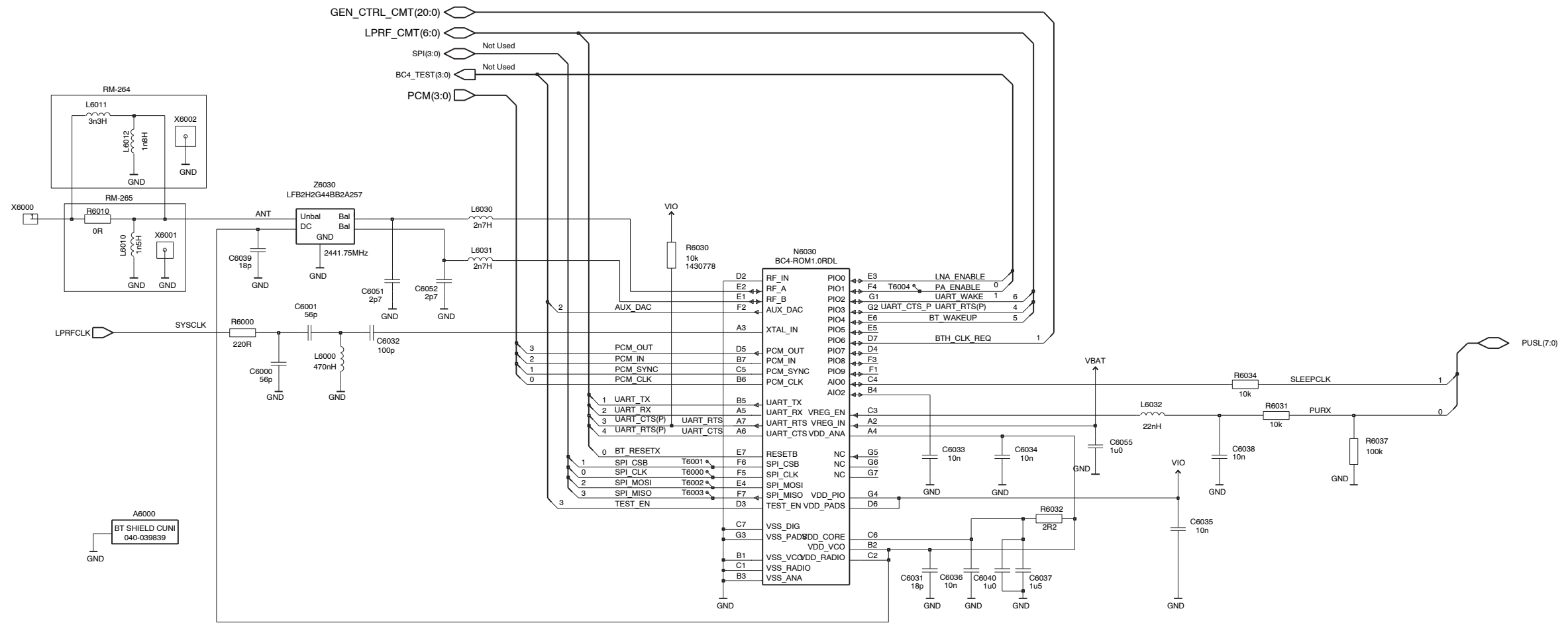



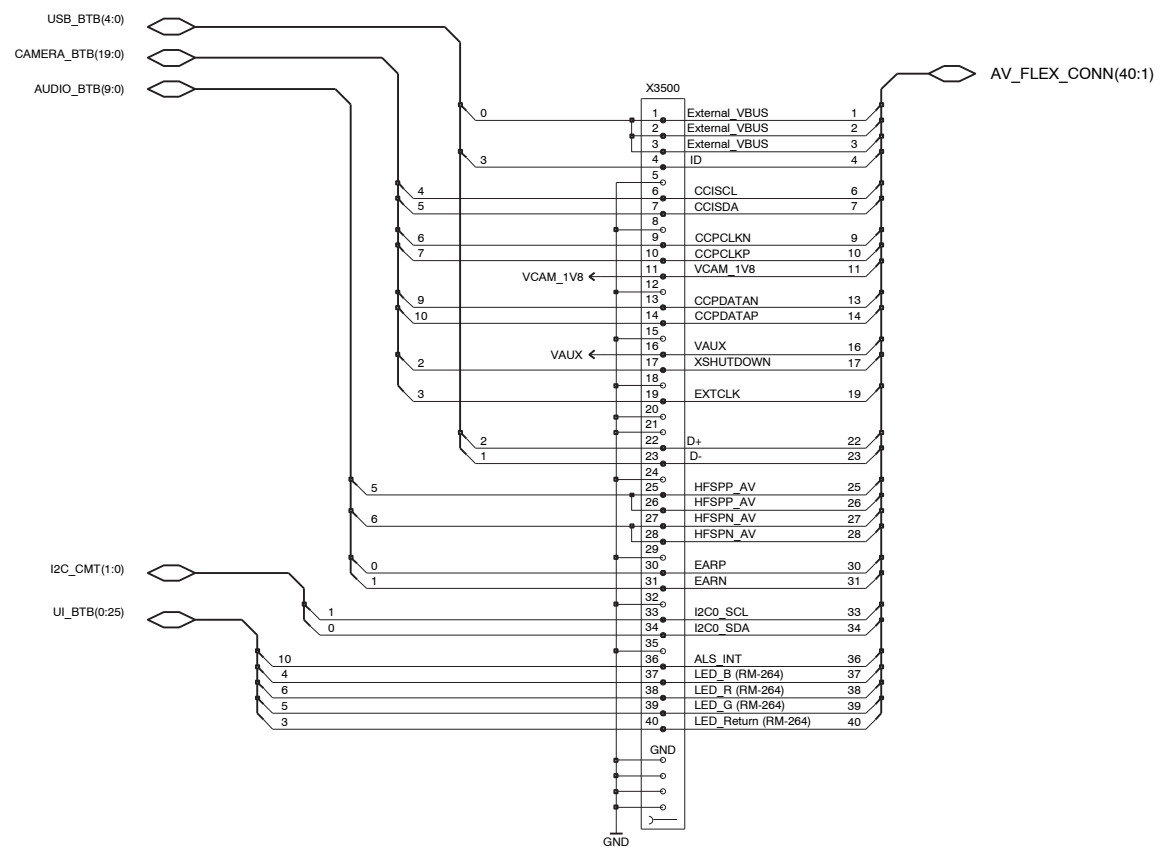

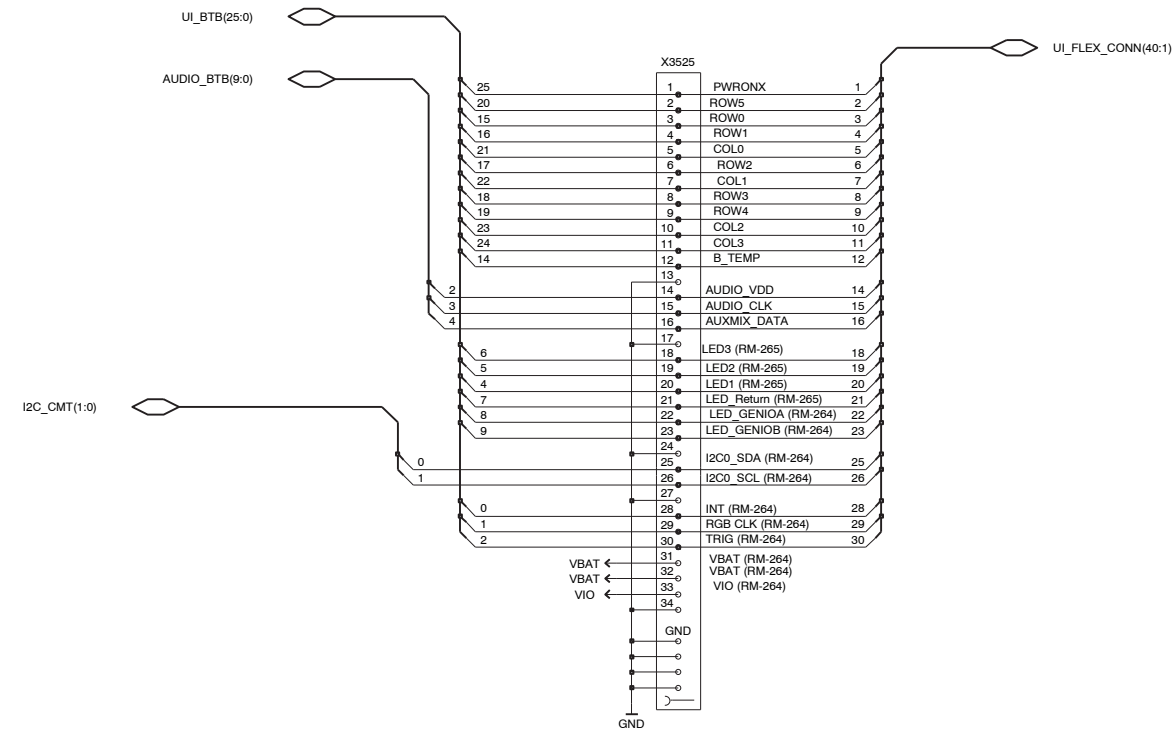

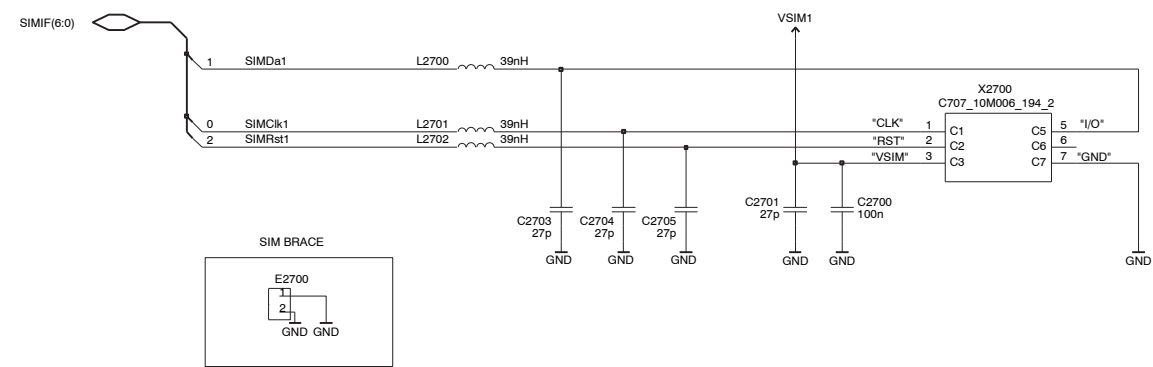

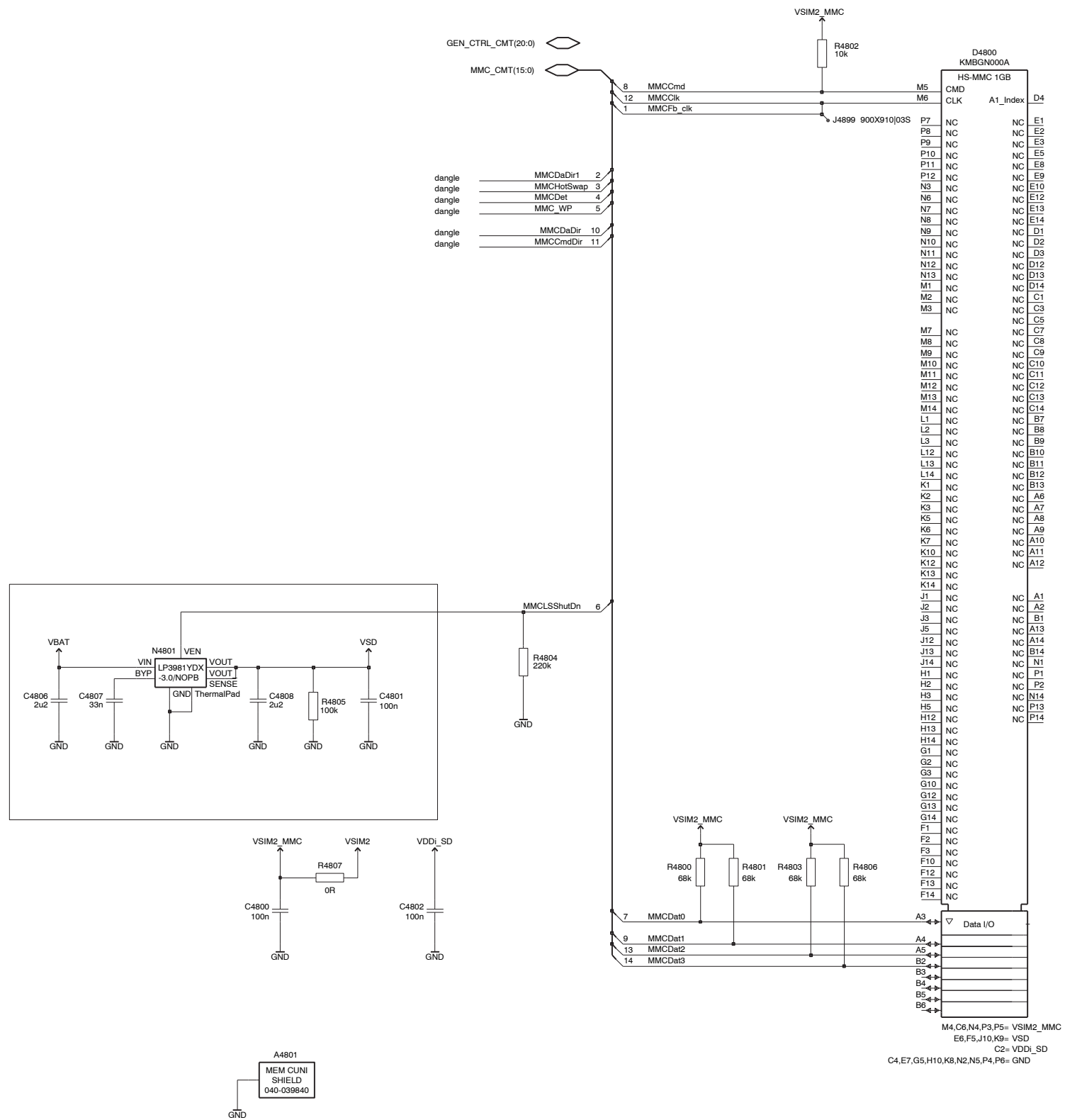

M4,C6,N4,P3,P5= VSIM2\_MMC  
 E6,F5,J10,K9= VSD  
 C2= VDDI\_SD  
 C4,E7,G5,H10,K8,N2,N5,F4,P6= GND

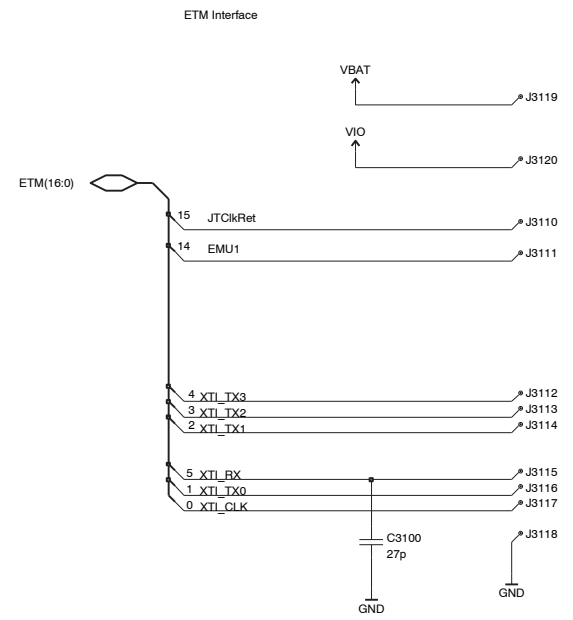
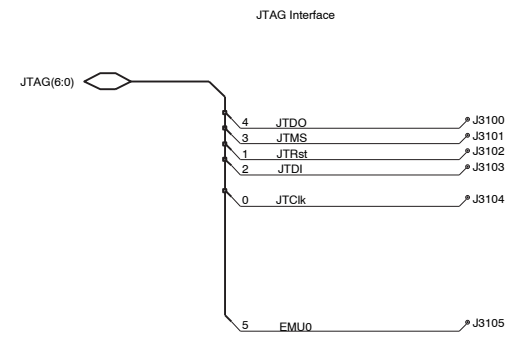

- RFCTRL\_I(8:0)
- FM\_CMT(2:0)
- GPS\_CMT(3:0)
- UI\_CTRL\_CMT(4:0)
- GPSCLK\_I
- CBUS(3:0)
- IRDA\_CMT(2:0)

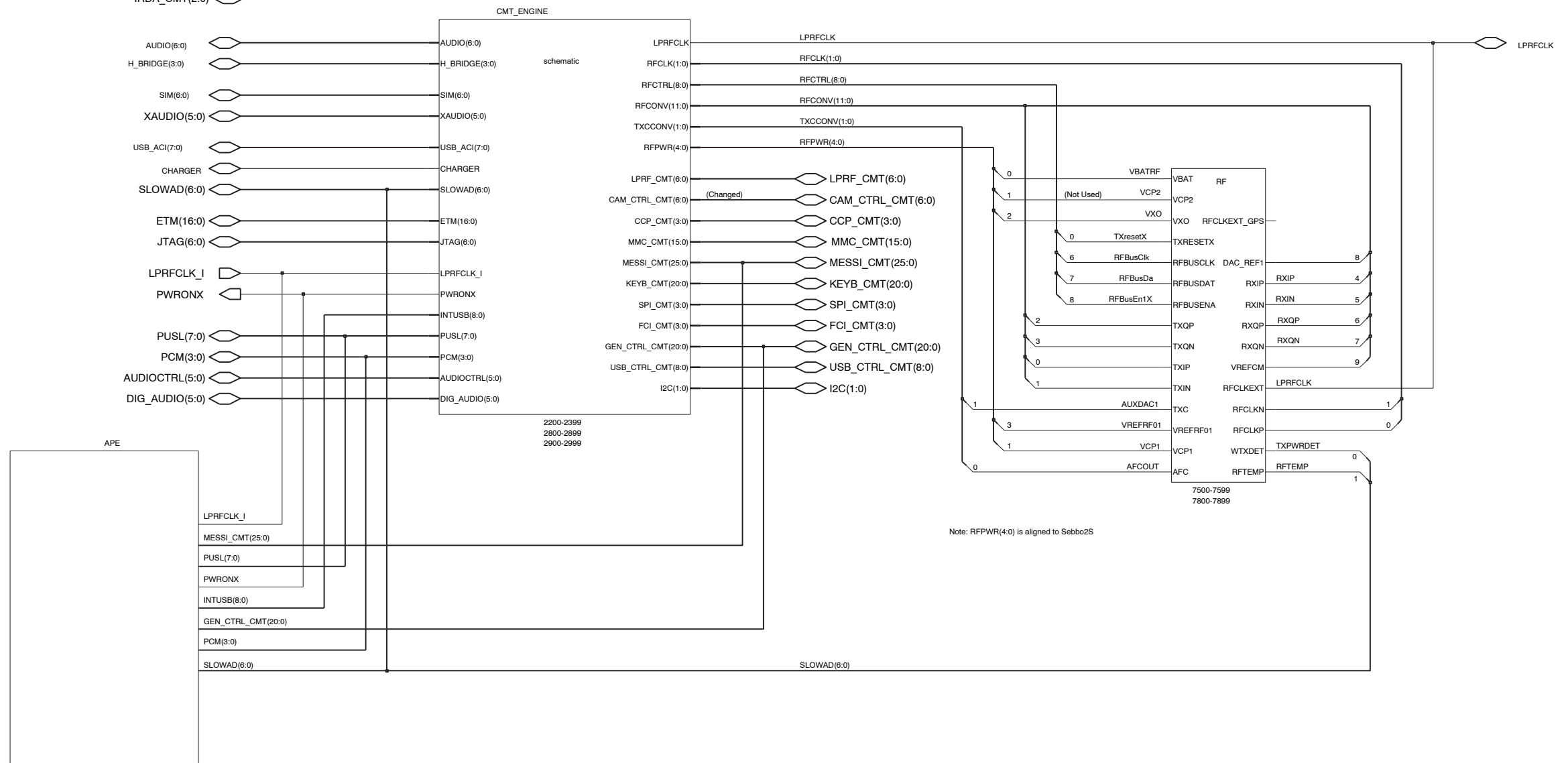

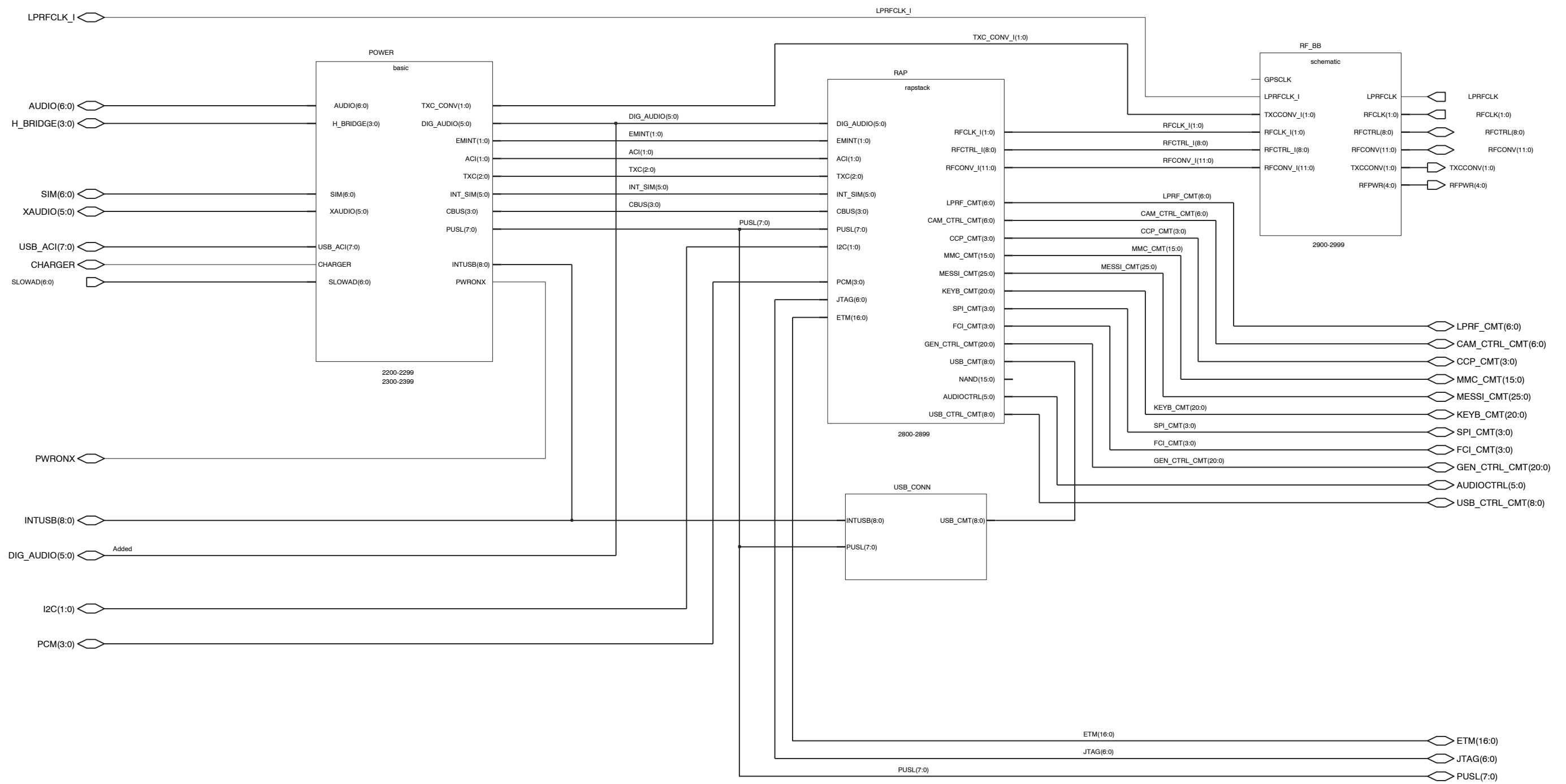

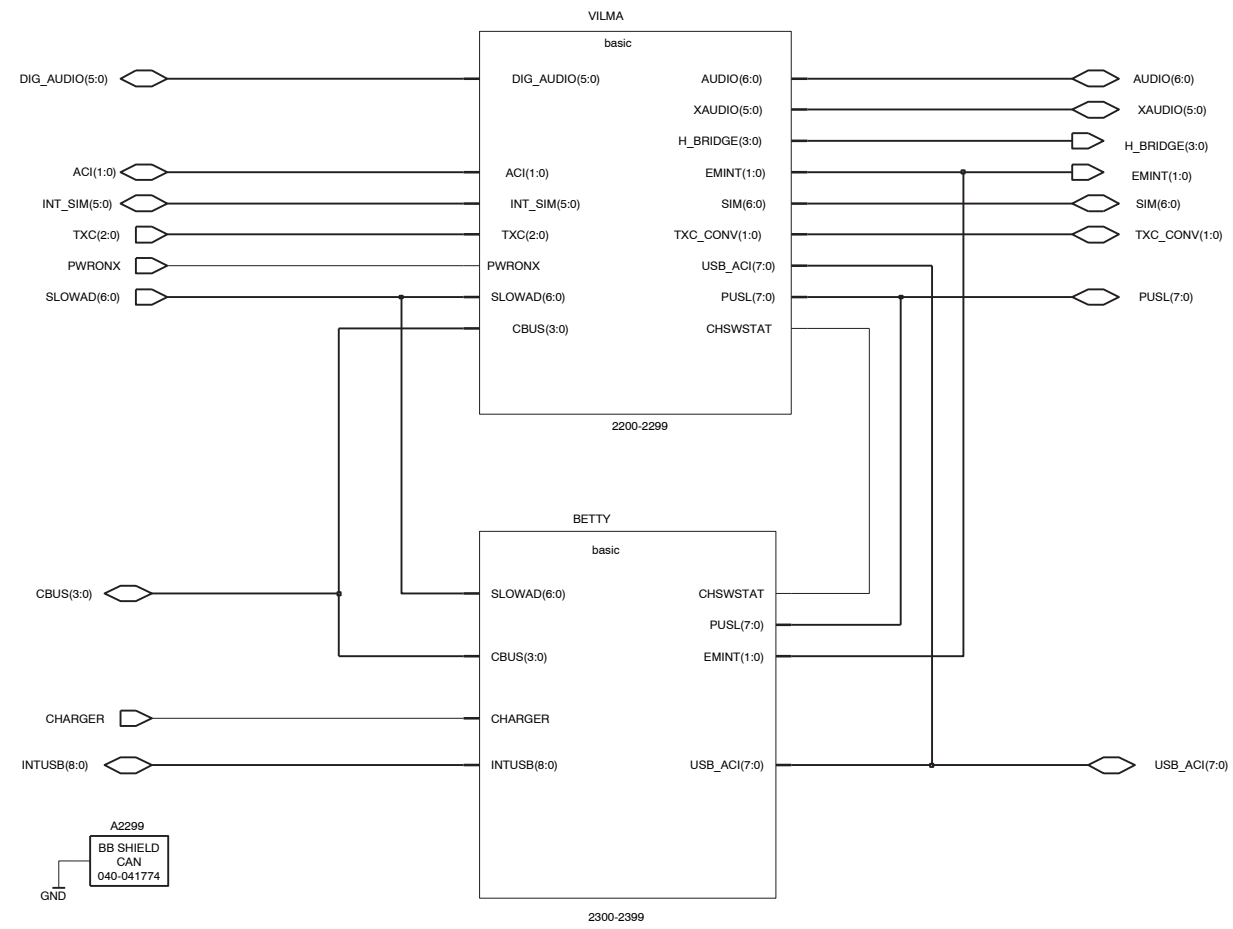



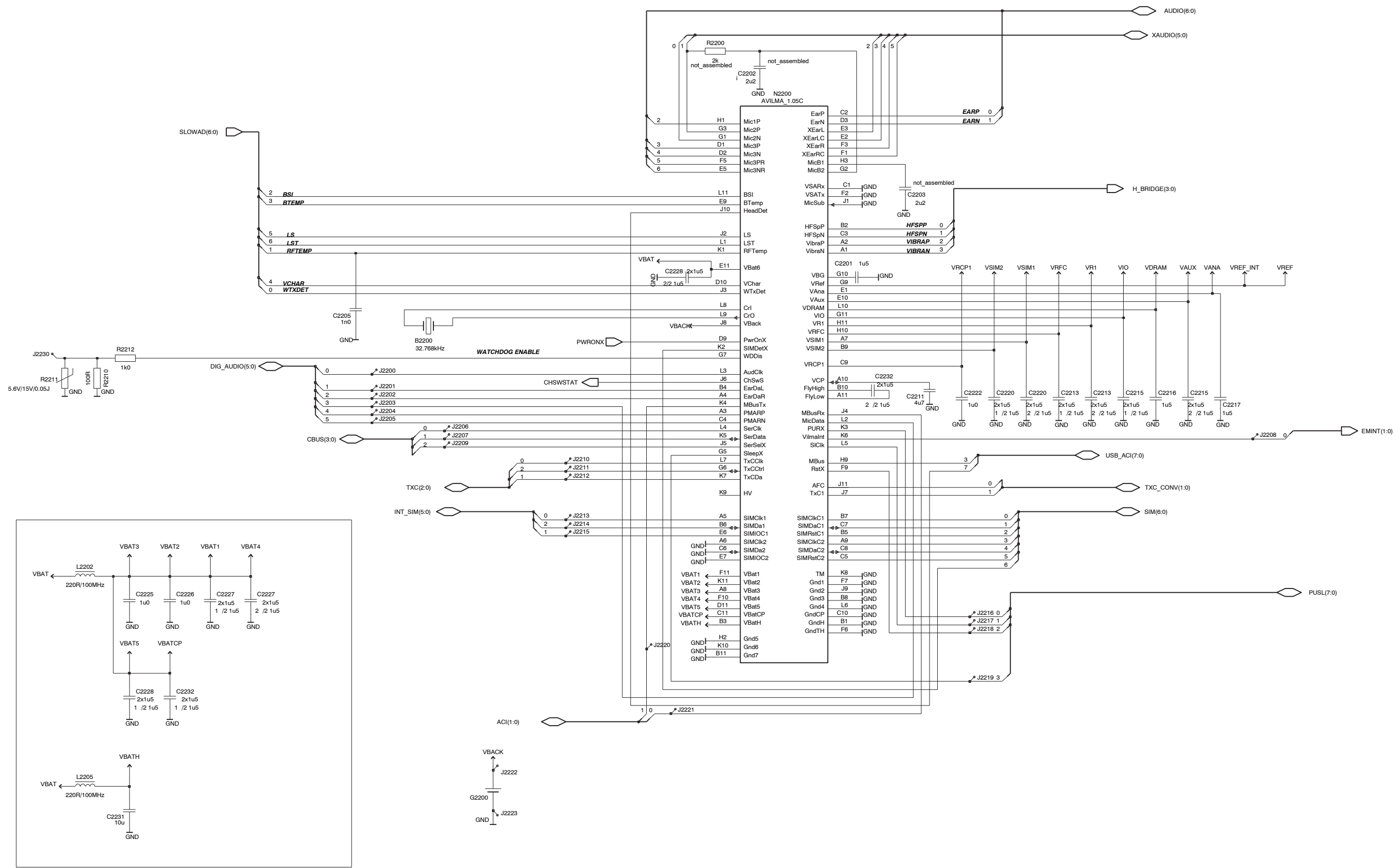

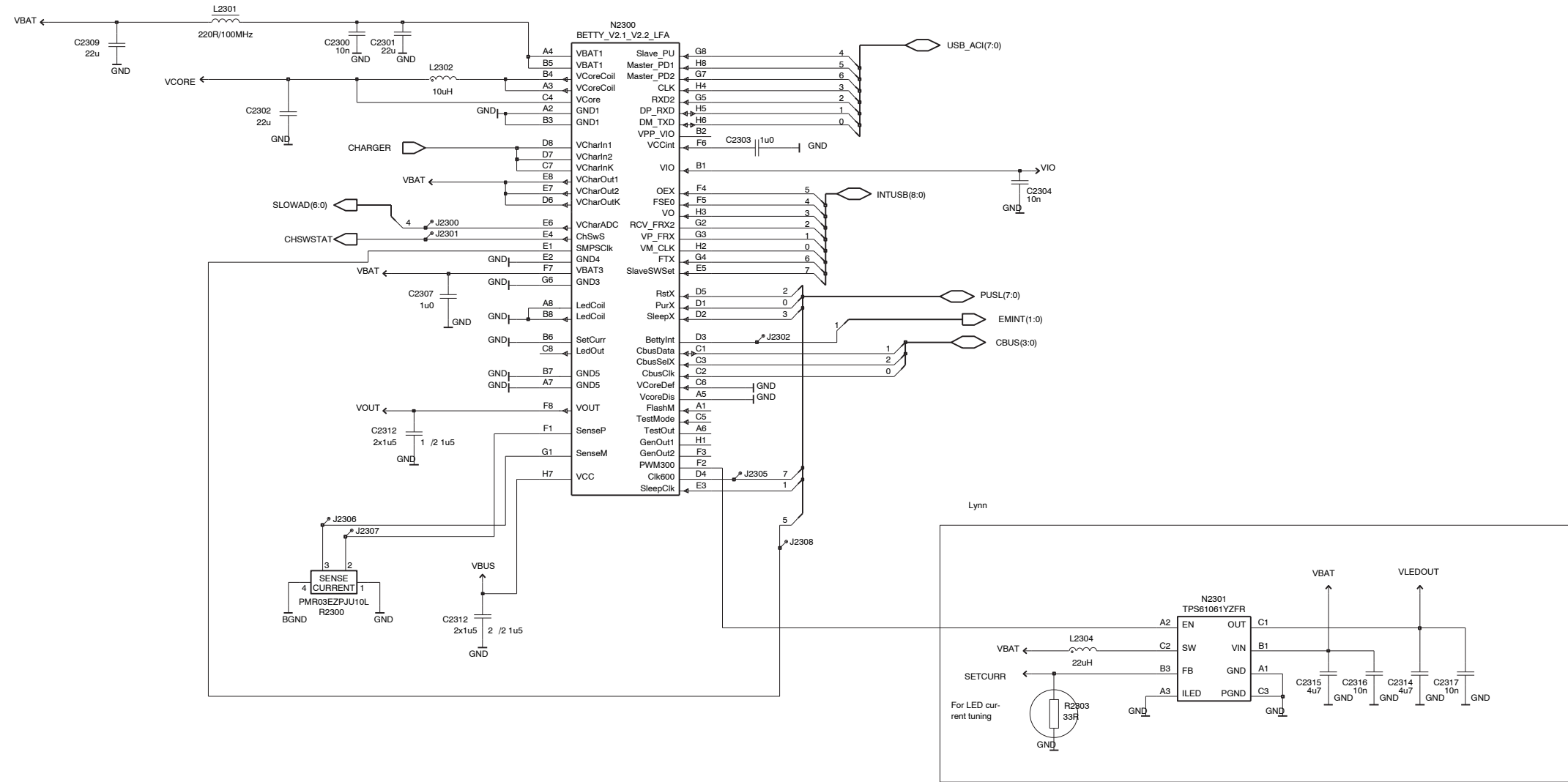

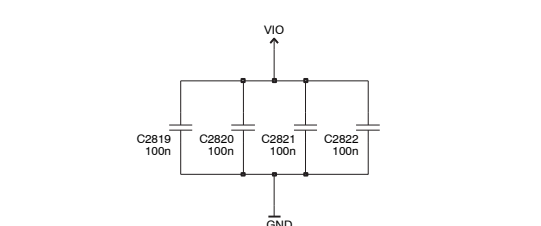
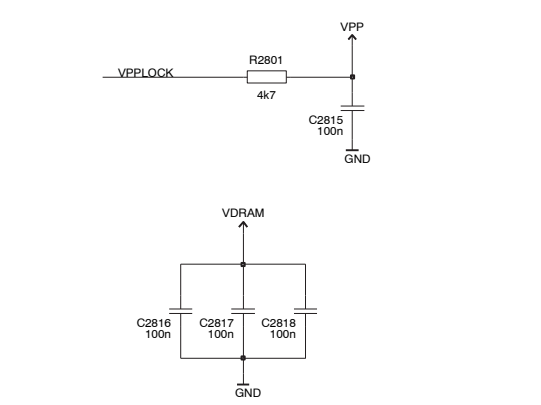
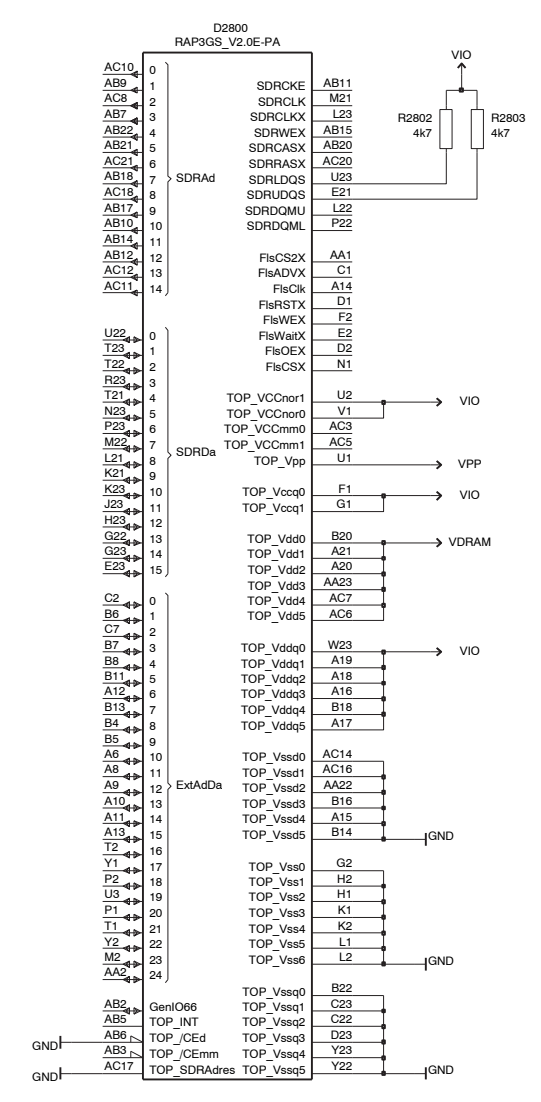
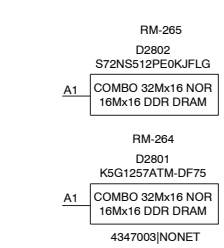
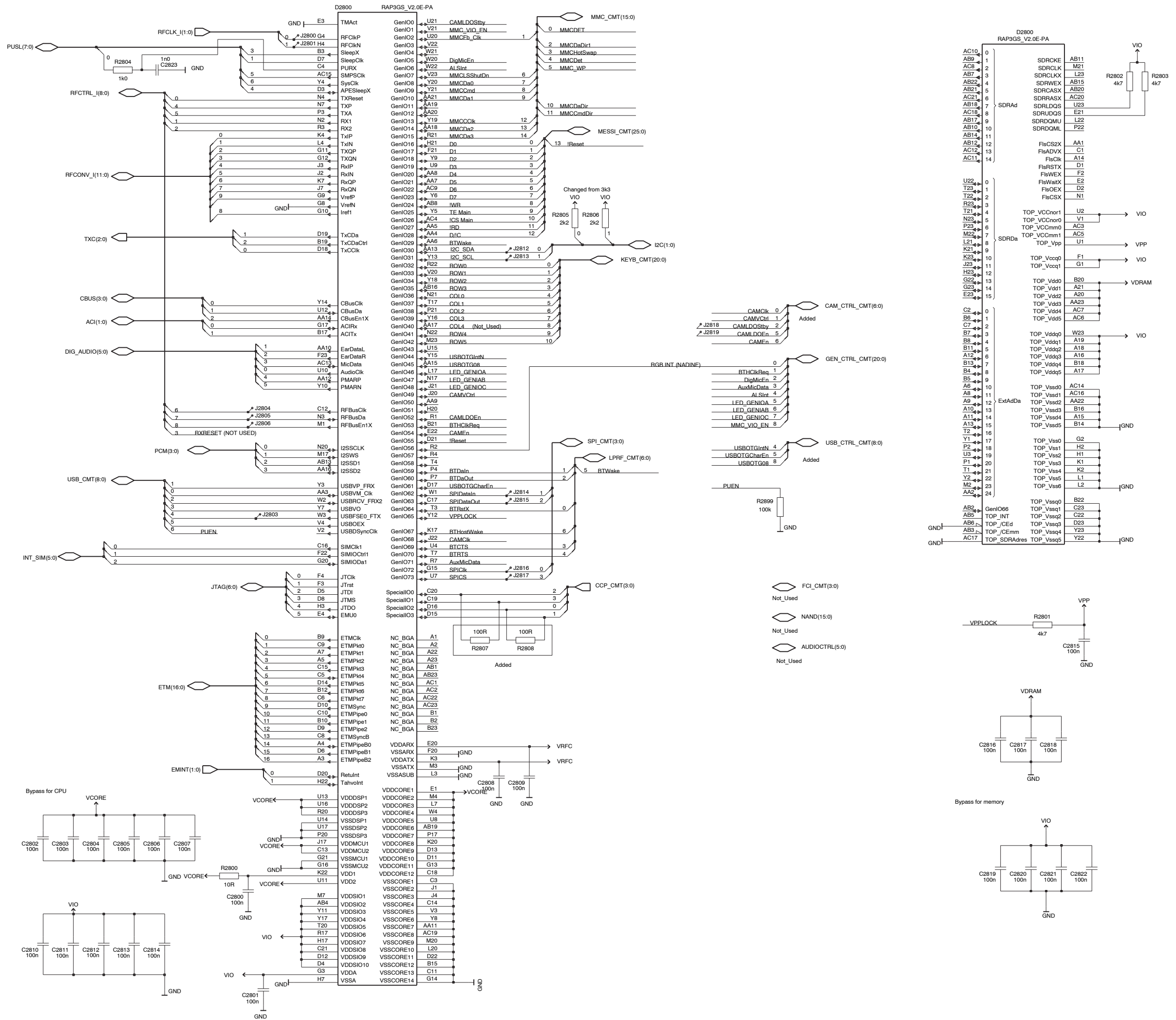

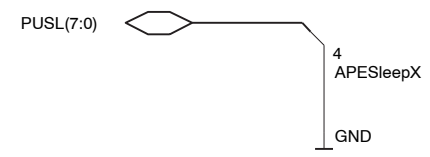
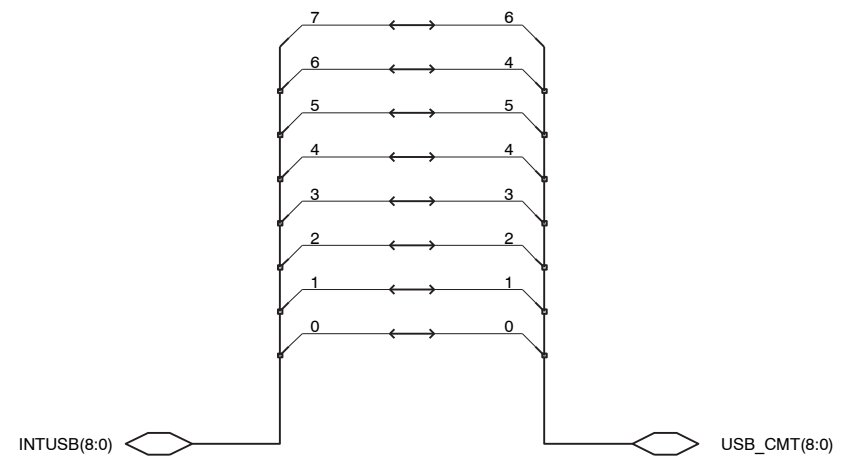

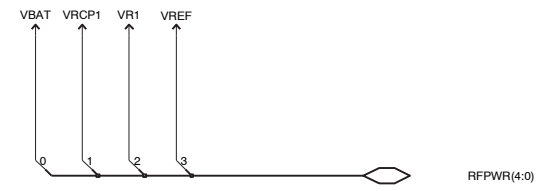
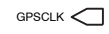
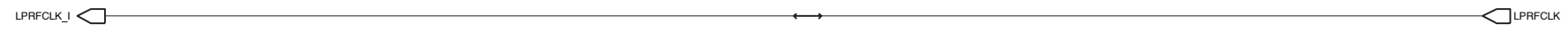



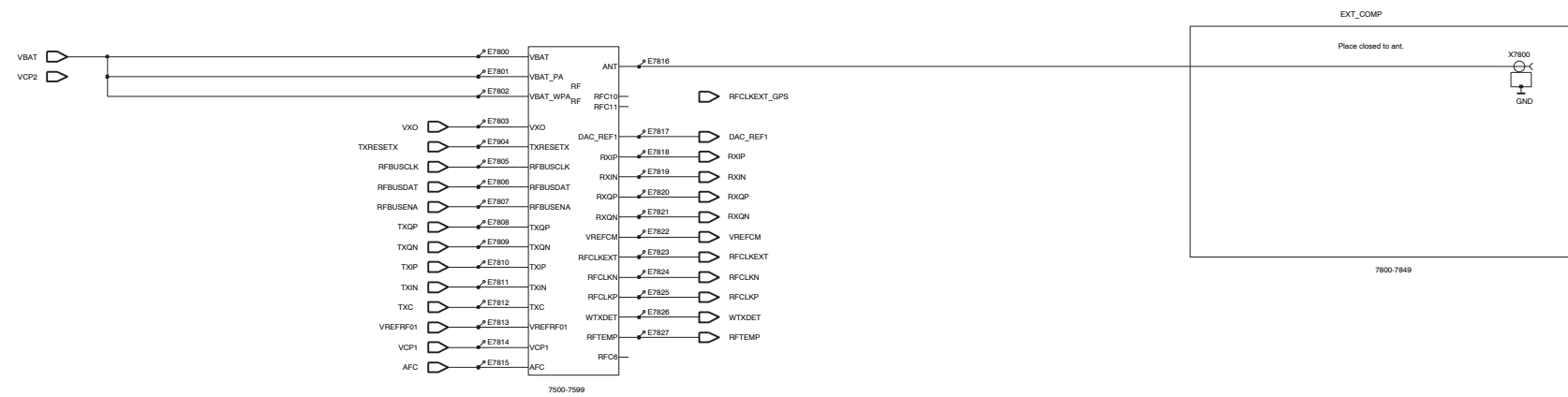





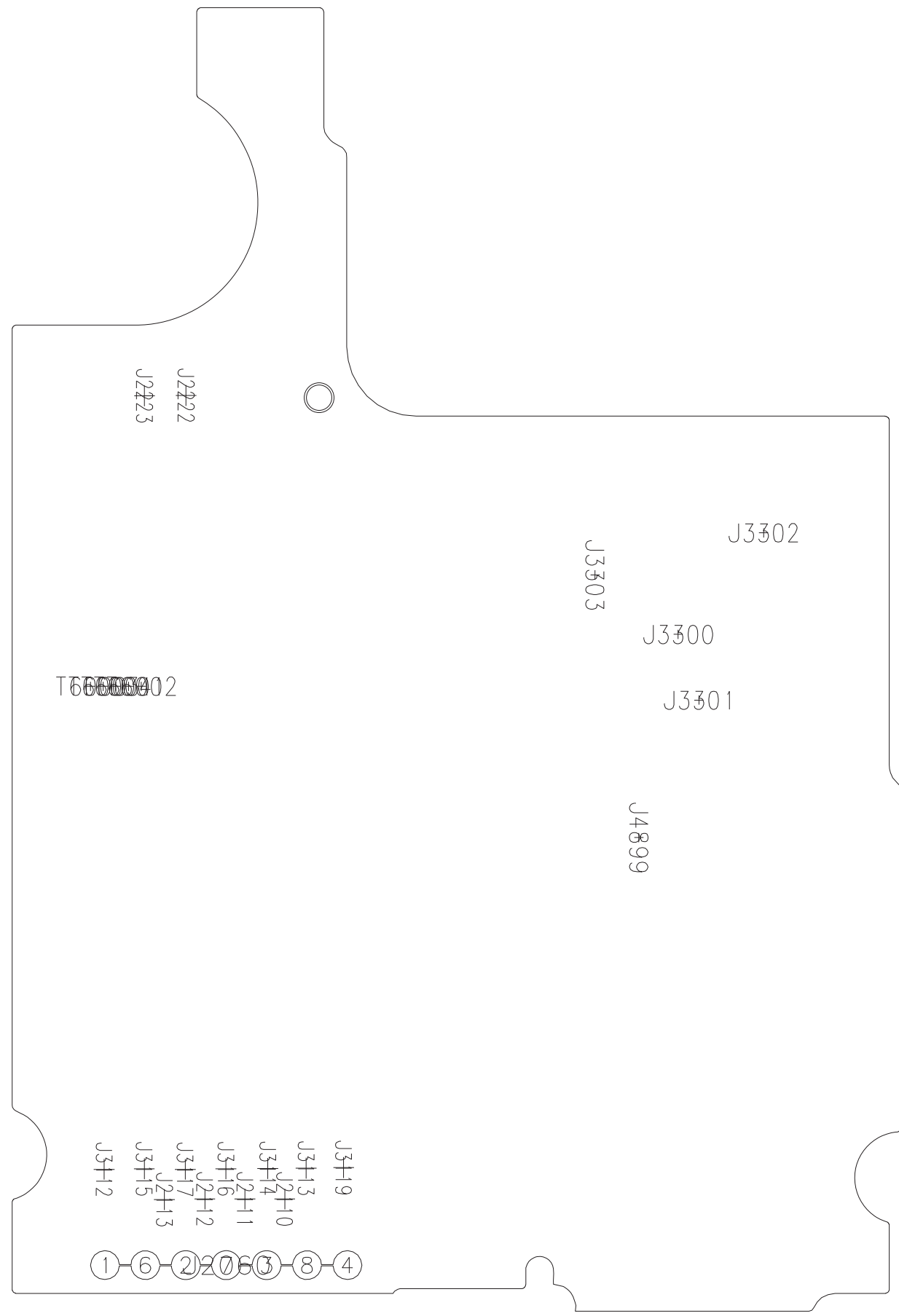

2dva\_06a\_Tp\_Drw\_B.385.pdf

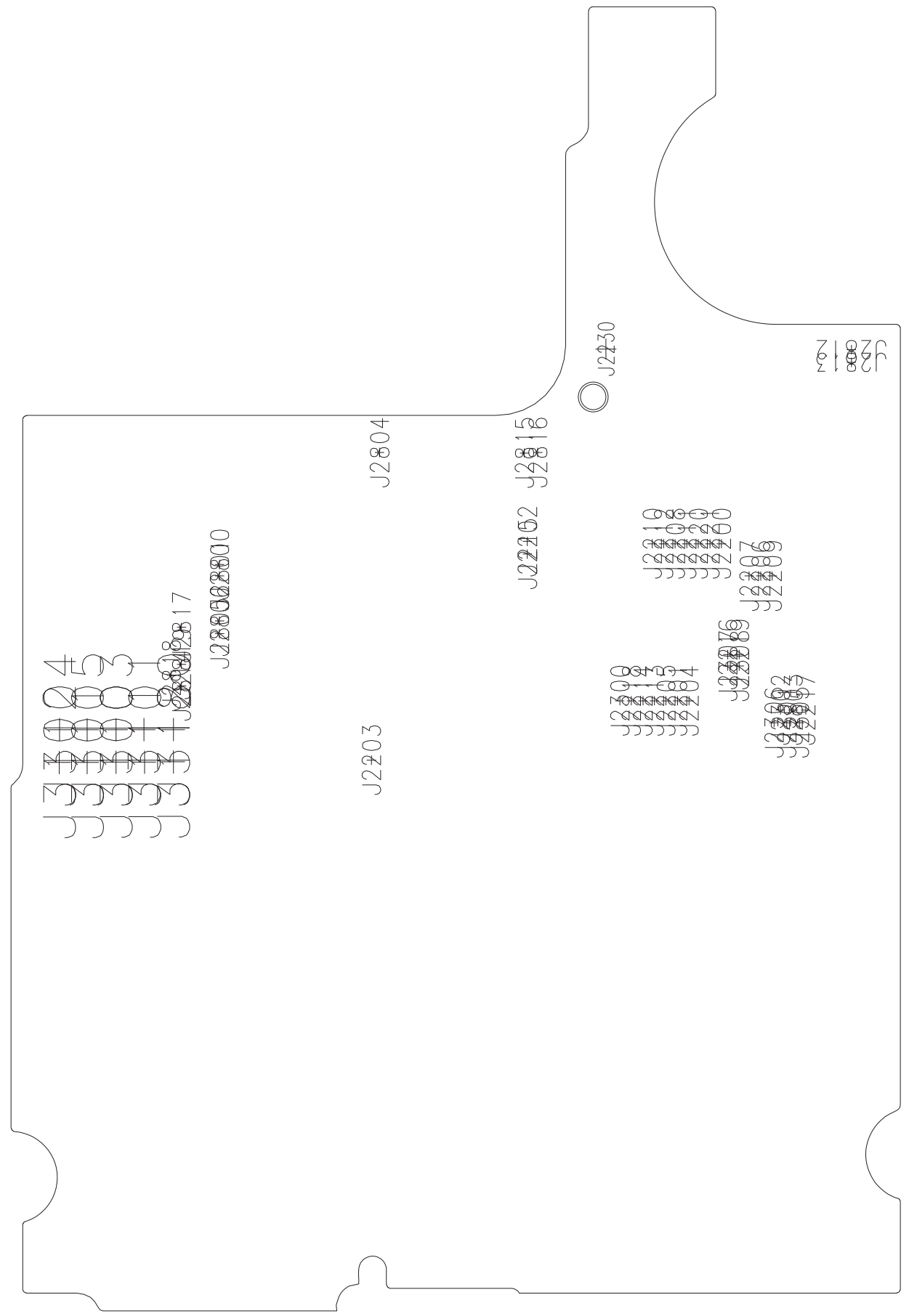

2dva\_06a\_Tp\_Drw\_T.385.pdf

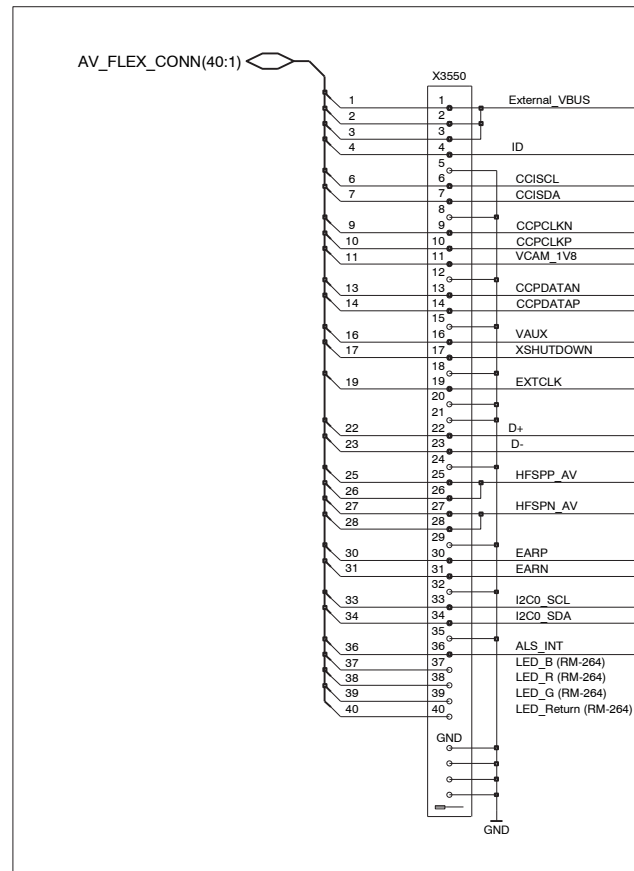

3550-3574  
Board\_to\_board

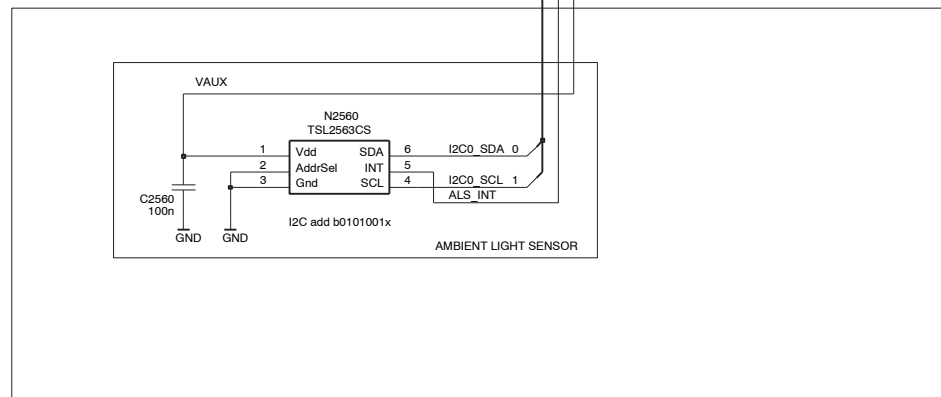

UI  
2560-2599

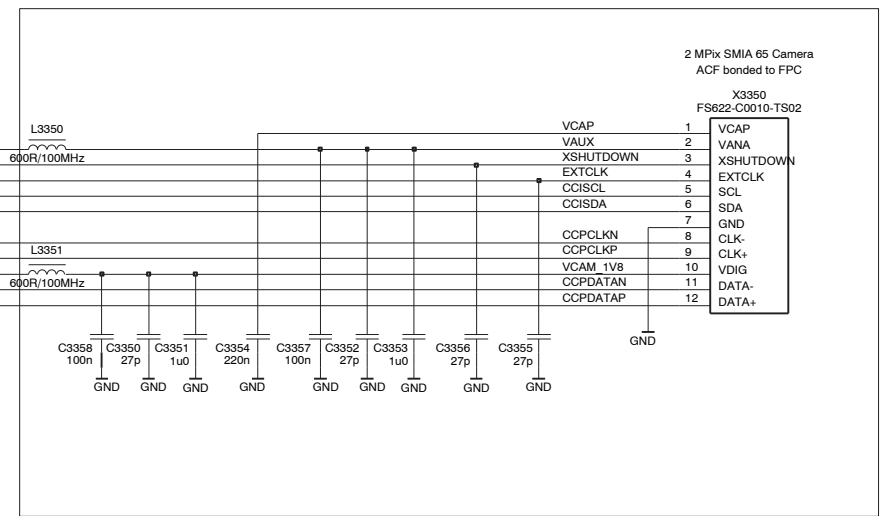
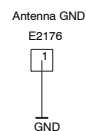

CAMERA  
3350-3379

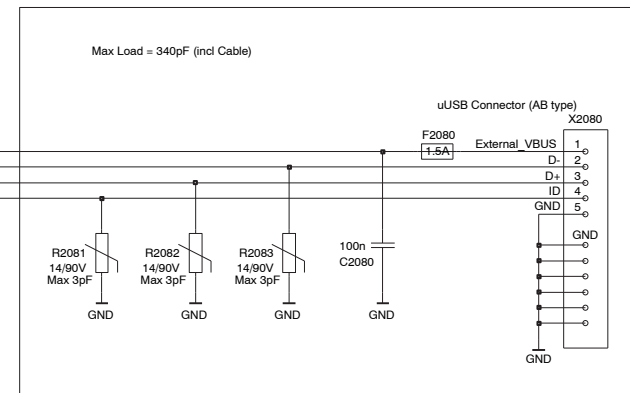

SYS\_CONN  
2080-2099

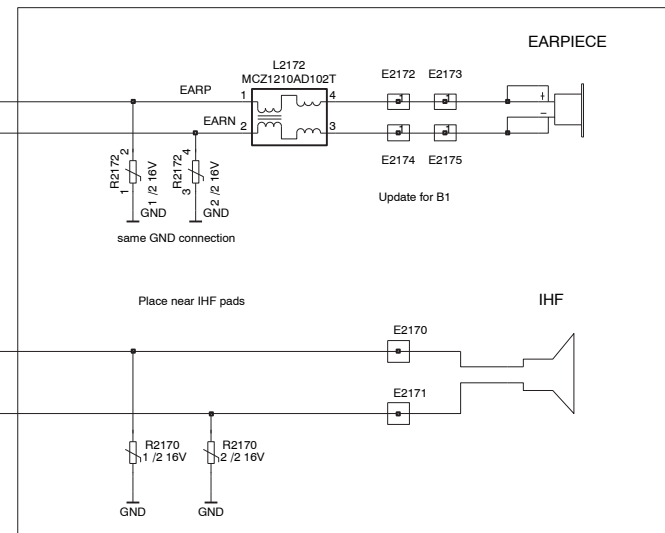

AUDIO  
2170-2184

2dvd\_04a\_asmdrw\_t.pdf

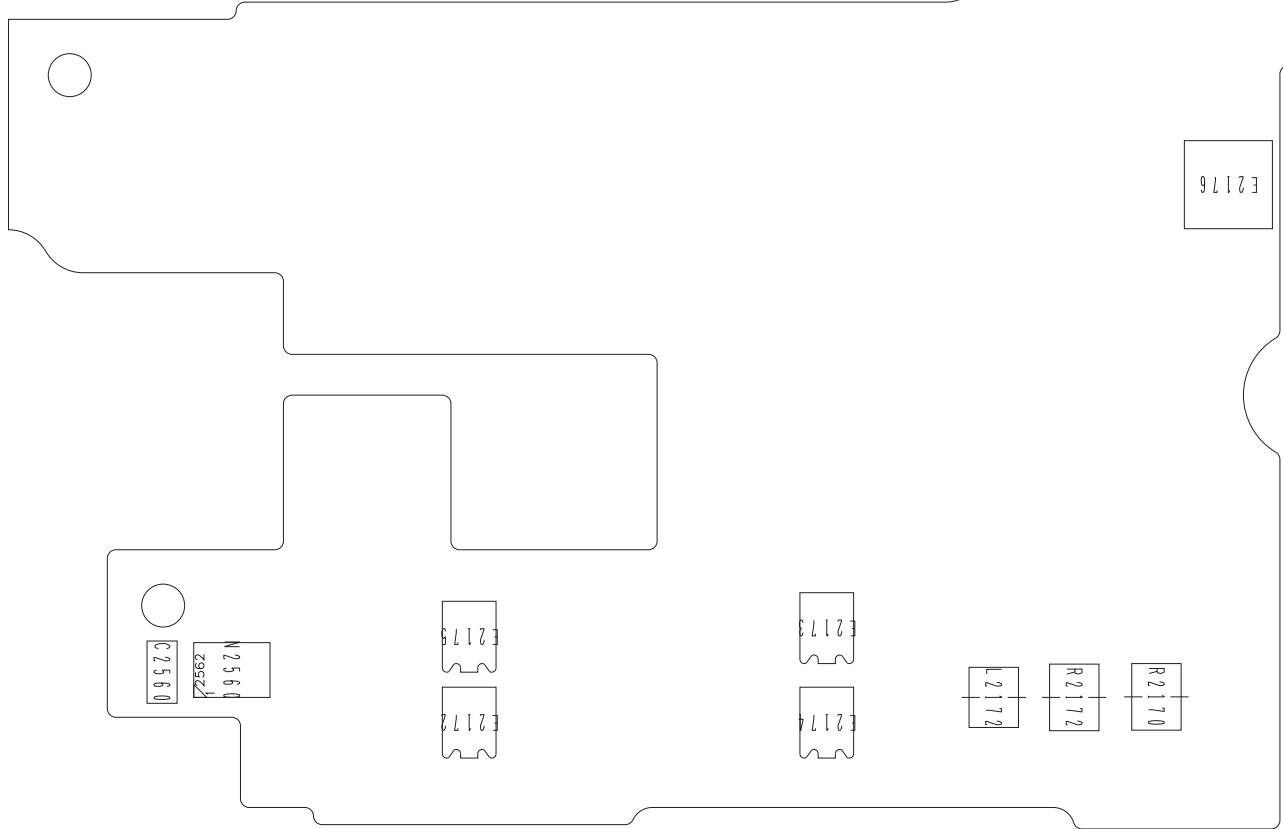

2dvd\_04a\_asmdrw\_b.pdf

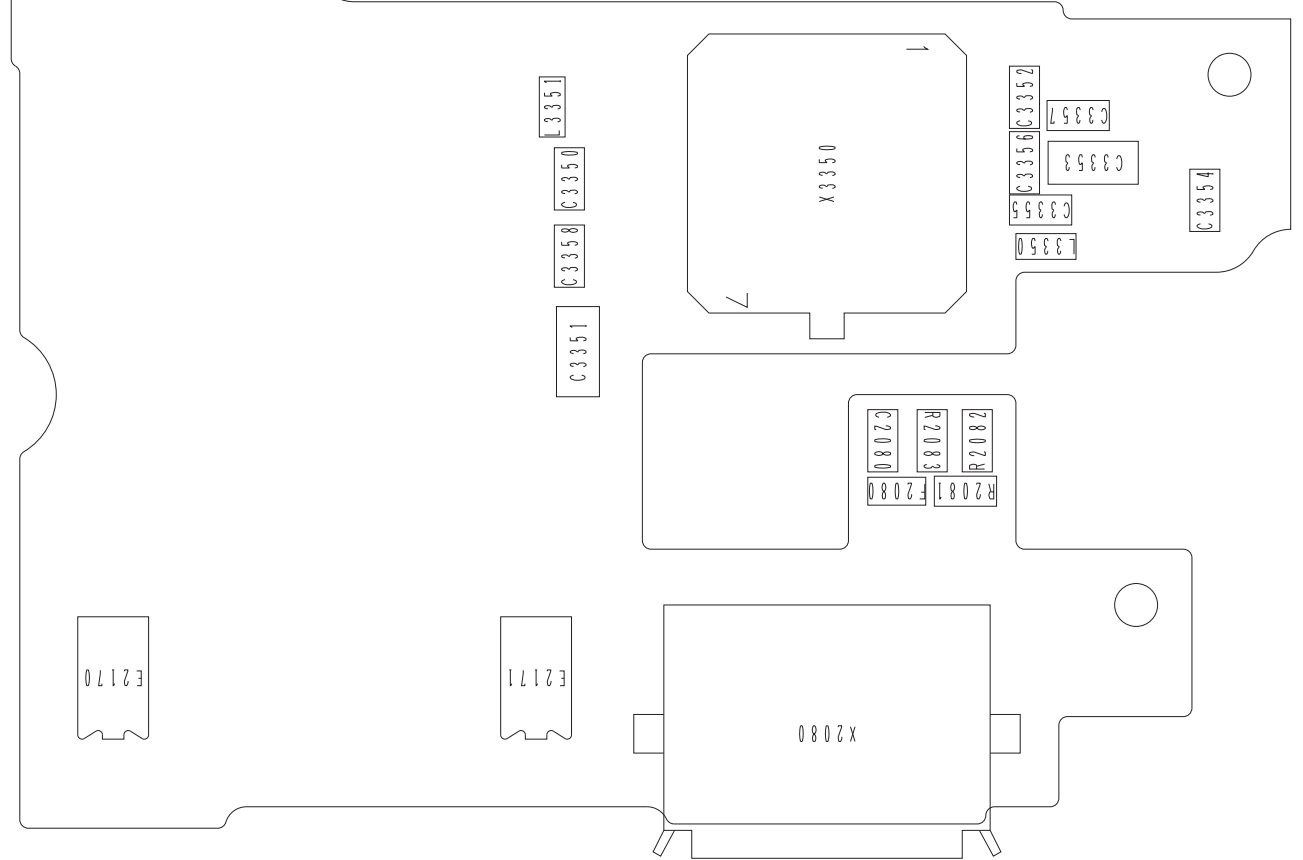

# Keyboard

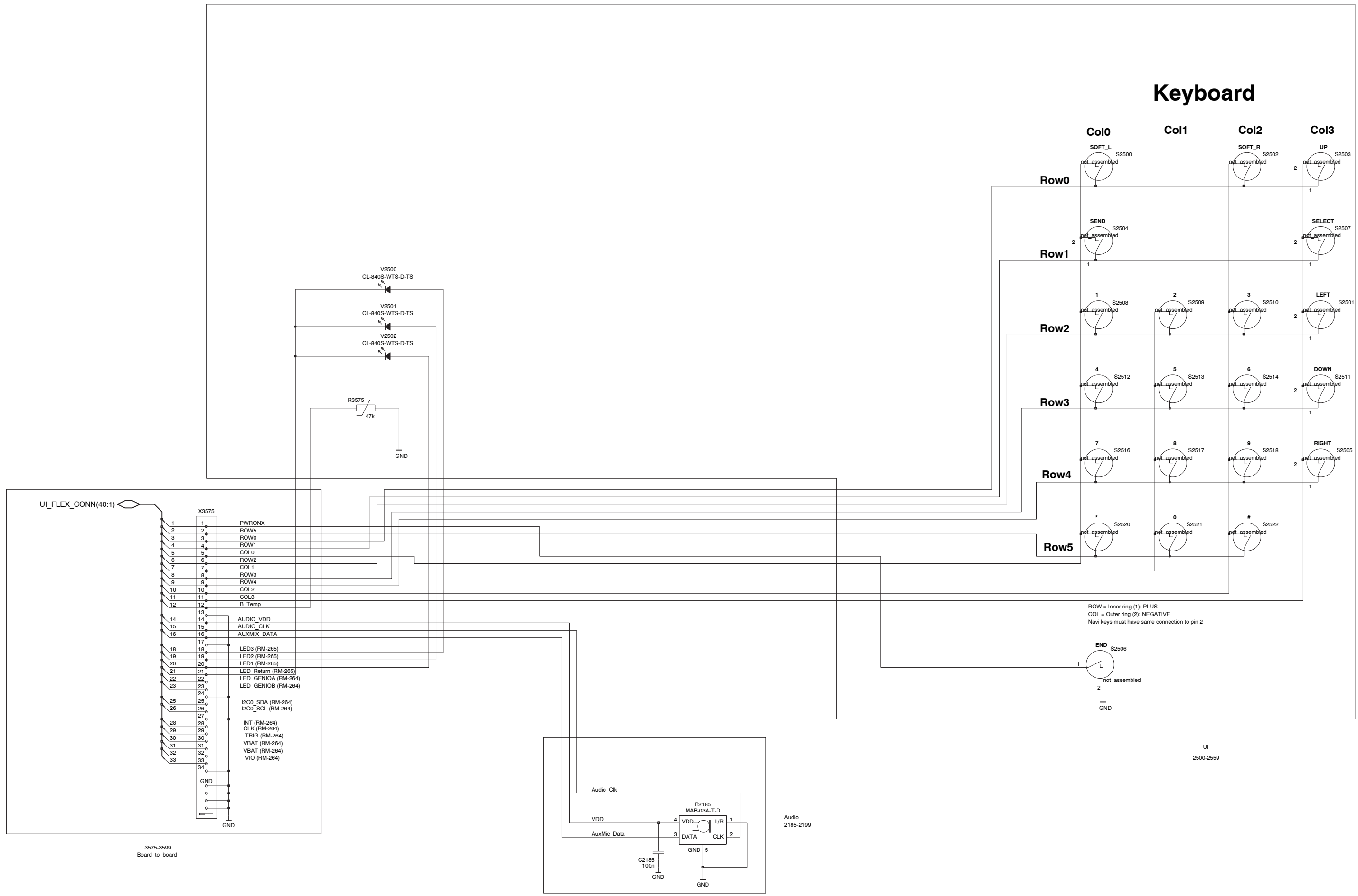

ROW = Inner ring (1): PLUS  
 COL = Outer ring (2): NEGATIVE  
 Navi keys must have same connection to pin 2

3575-3599  
 Board\_to\_board

Audio  
 2185-2199

UI  
 2500-2559

2dvd\_02a\_asmdrw\_t.pdf

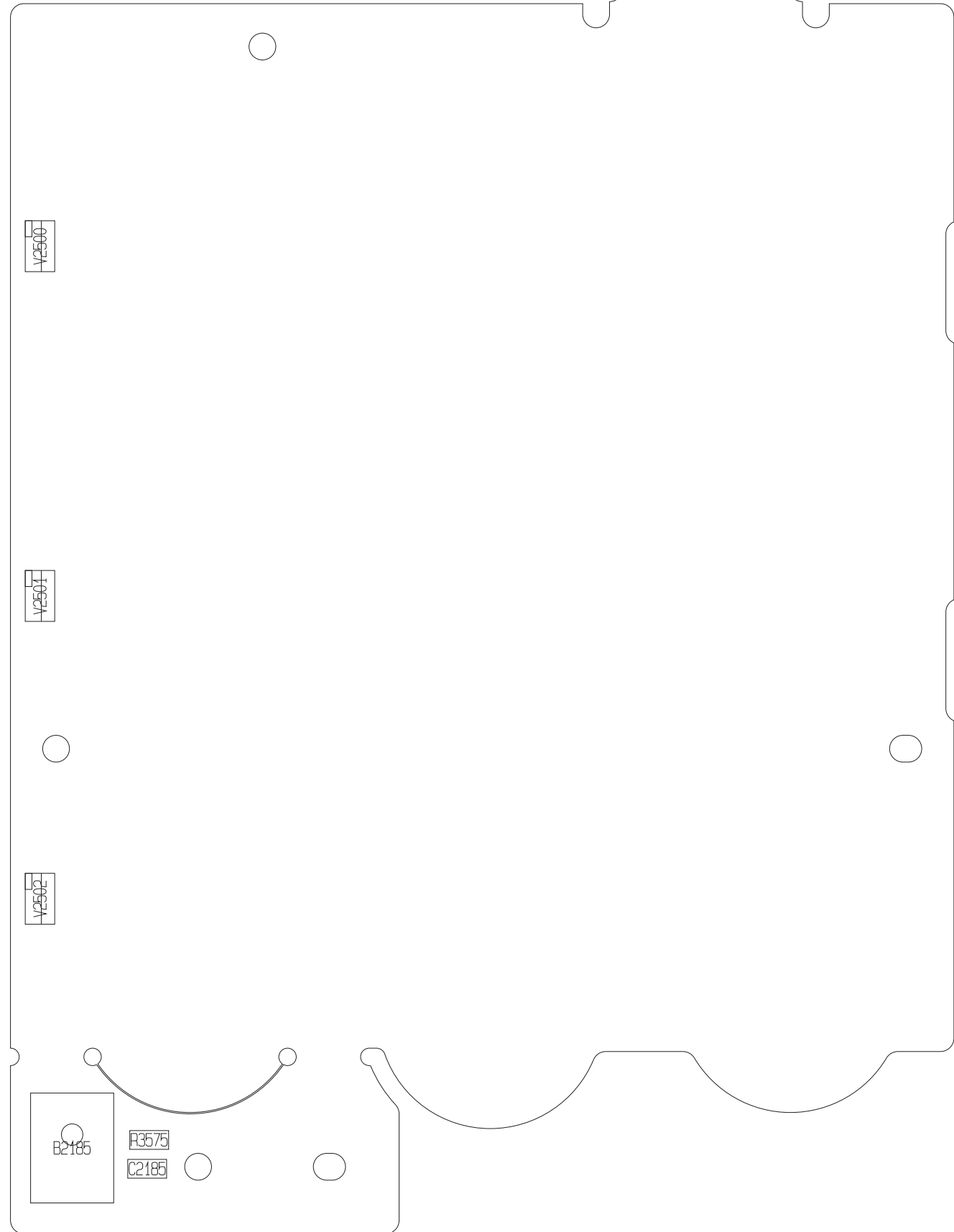

X3575

2dvd\_02a\_asmdrw\_b.pdf

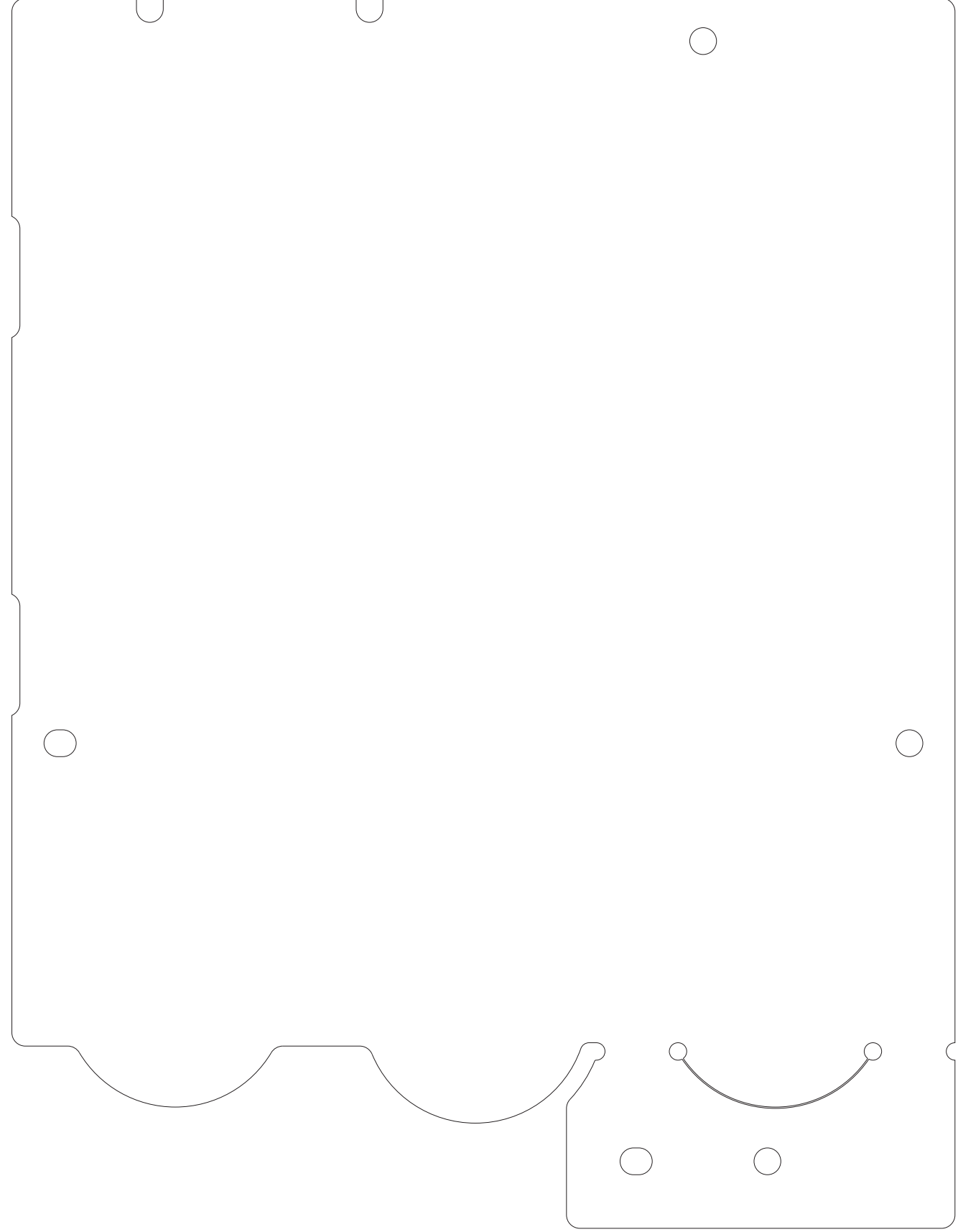

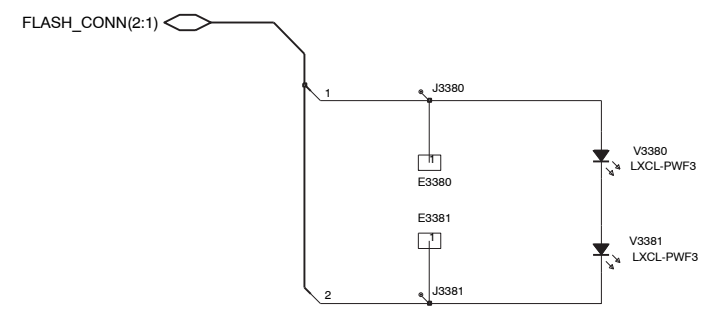

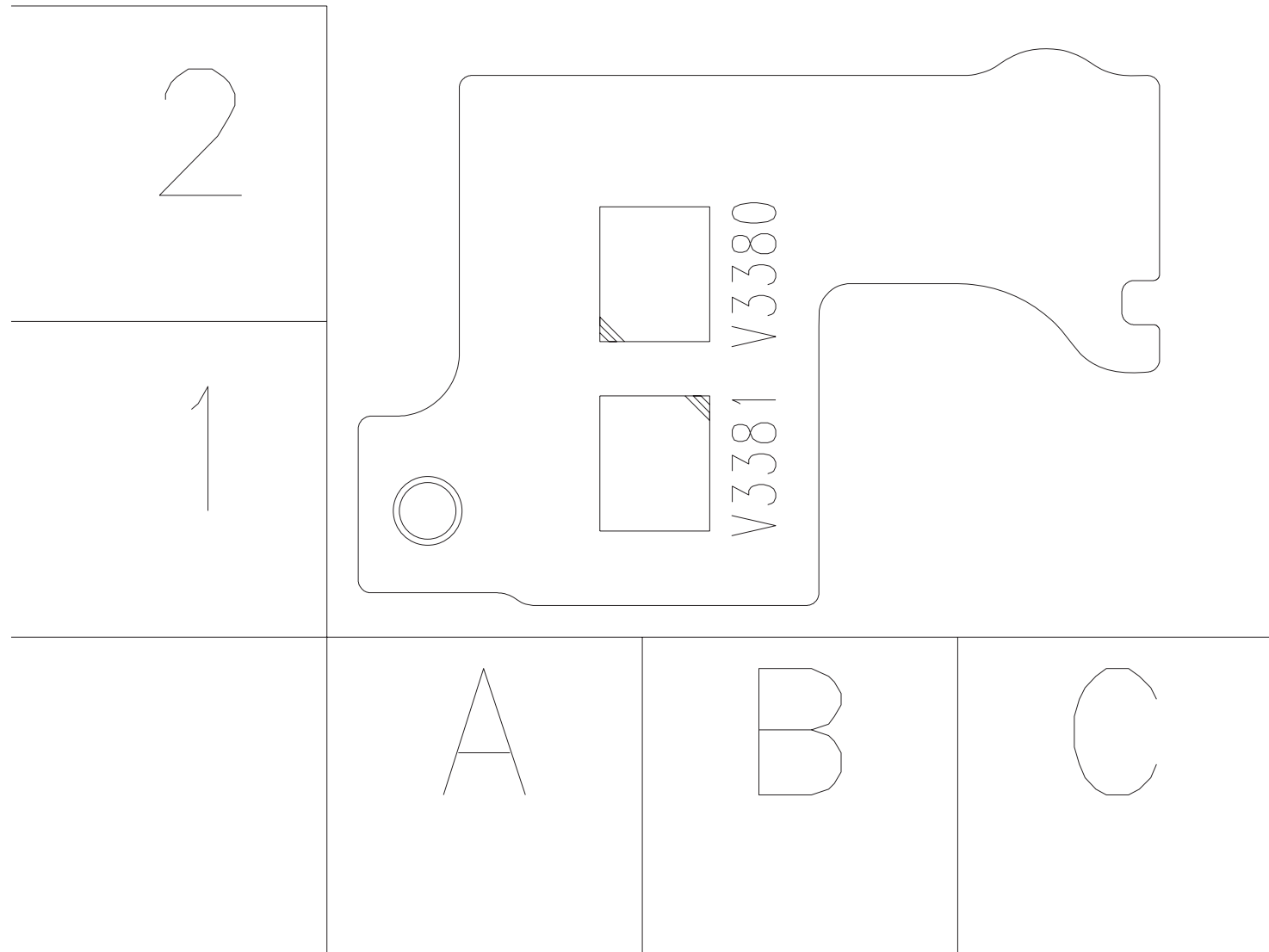

2dvf\_02a\_AsmDrw\_T.15.pdf

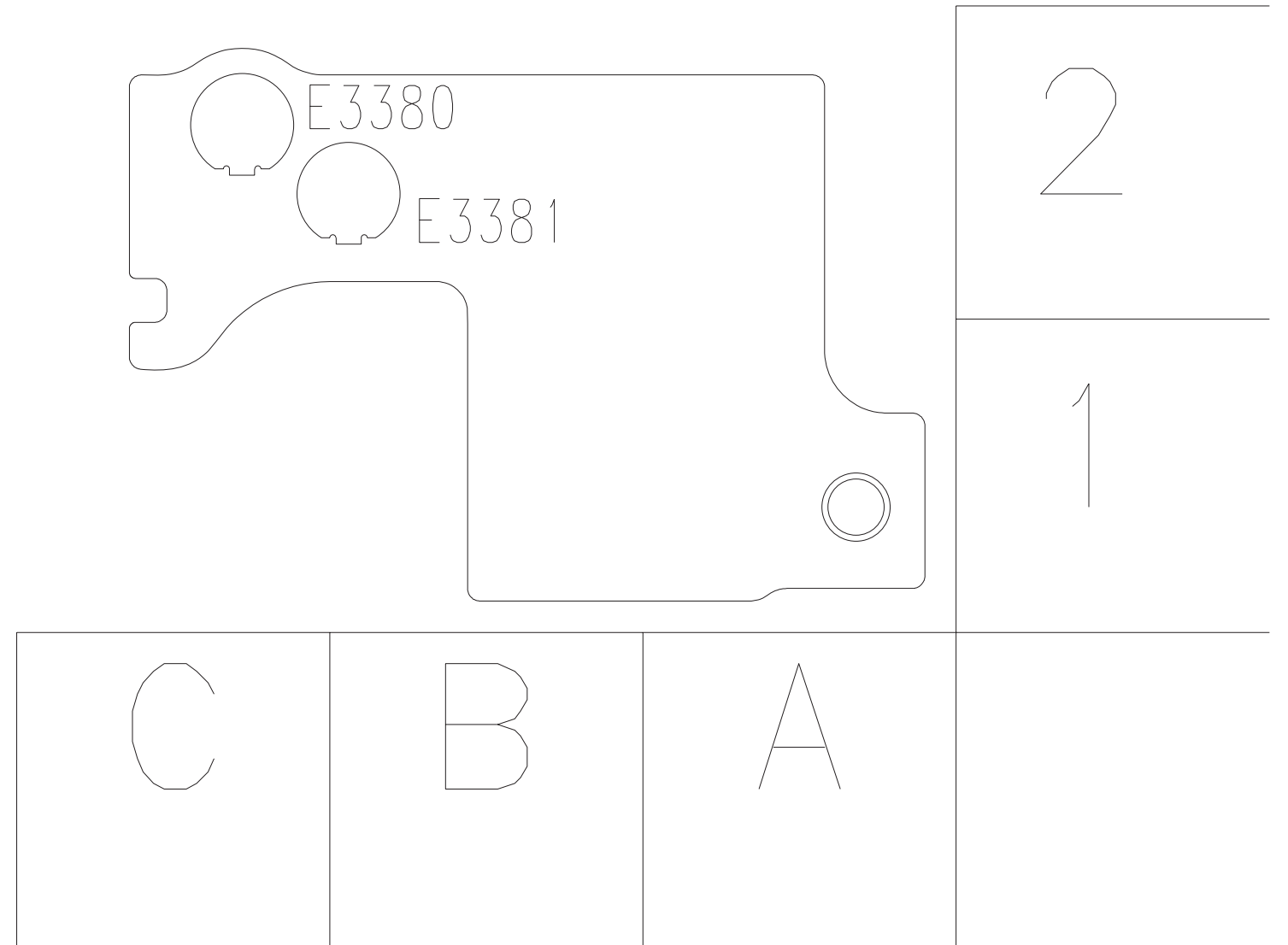

2dvf\_02a\_AsmDrw\_B.15.pdf

J3380

+

+

J3380

Ø